



**DIGITEL**

**enviro-sense**

[www.digitel-ag.com](http://www.digitel-ag.com)

Product Overview

Digitel High Volume Samplers





Measurement site of NABEL, Jungfrauoch, 3578 AMSL, Switzerland  
First measurement site with Digitel Samplers 1972,  
after 25 years an automatic sampler DHA-80 was installed.

# Content

Pictures	3
Who we are and what we want	5
Enviro-Sense	7
Enviro-Drive	9
Our High Volume Air Samplers	10
DIGITEL Aerosol Sampler DHA-80	11
DHA-80 Compressor Cooled Sample Storage	13
DIGITEL Aerosol Sampler DH-77	15
DIGITEL Blower DS-02	15
Options	17
Cartridges	17
Data logging	18
Meteo sensors	18
Accessories	20
Inlets	20
Sampling	23
Installation	24
Calibration	26
Spare Parts	27
Consumables	27
Contact	28

# Pictures

Cover: NABEL measurement site Seebodenalp, 1031 AMSL., Switzerland	
Measurement site of NABEL, Jungfrauojoch, 3578 AMSL, Switzerland	2
Measurement site in southern Styria, Austria	4
Measurement site on Cap Verden	6
Measurement site in Spain	8
Background measurement site in Scotland	16
Measurement site on Sonnblick, 3106 AMSL, Austria	19
Measurement site in Magadino, Switzerland	25





Measurement site in southern Styria, Austria

# Who we are and what we want



## We develop and manufacture Aerosol, Gas and Wet-only Samplers

We offer:

- Reliable, compact, robust, economical and long-lasting sampler systems (more than 1500 installed units)
- A wide range of accessories
- A constant development to provide the most technically advanced sampling products
- Individual customer care
- Customized designs and developments

## Digitel – Europe Wide Service

We want to ensure our customer's satisfaction at all times. This includes a network of local sales representatives, who are well trained on Digitel instruments and can help the customers with all requests. In case even the representatives cannot help, we hit the road to apply our 40 years of experience in the environmental measurement sector for our customers.

Our instruments have been in use for over 30 years, we stand for highest quality.

We are the leading supplier for customized solutions in the environmental measurement sector. We develop implementations using up-to-date CAD computer programs and CNC manufacturing machines. We use different materials and designs innovatively to find the best solution for our customer's applications. With our modern development and machinery infrastructure, we are ready to offer competitive prices for high quality developments.





DHA-80 on Cap Verden Islands



## DIGITEL "enviro-sense" – definition for environmental compatible acting

DIGITEL's automatic aerosol, gas and wet-only sampler represent an impressive composition of ecology and economy. They are geared to the requirements of a long-term intact environment and so to a healthy and livable future.

Our sensitivity „sense“ to questions concerning the environment „enviro“ is turning enviro-sense reality.



In all our products.

The results are:

- Optimized production process with conscious abandonment of raw materials and operating recourses which burden the environment
- Use of recyclable and degradable materials
- Application of well-engineered electronics with the least energy demand
- Construction for long life time and error free function at small expenditure

The aerosol, gas and wet-only sampler of DIGITEL unify specialized know-how, experience, quality and ecology – since 1970.





Measurement site in Spain





## DIGITEL "enviro-drive" - the environmentally compatible drive of the our devices

The accurate long term stability of the air quantity forms the central element of all DIGITEL High Volume and Low Volume Samplers. It is guaranteed by the DIGITEL developed sample quantity regulation: use of a flow meter with float (rotameter)



- Two adjustable photo cells scan the upper edges of the float
- The signal of the photo cell triggers the electronic frequency converter
- Generated from the AC mains, the three-phase electric power runs the DIGITEL high frequency blower/ oil-less rotary air compressor, depending on the needed rotational speed of the turbine
- By collecting all relevant data and events the continuous pressure and temperature measurement serves the exact determination of the sampled quantity

The DIGITEL control system with the flow meter as reference value results in a minimum pressure drop at the control system and turns the recalibration of the flow rate redundant. The pressure drop in the device is reduced by the absence of critical openings and blinds as well as by the optimized air flow conduction layout. In consequence, the rotational speed of the blower is dropped to the absolute minimum which results in obvious advantages:

- Low consumption of electricity
- Low abrasion
- Less noise
- Minimum heating of the extracted air
- Due to their similar mode of operation, systems with a flow meter are especially qualified to work with nozzle impactors

# Our High Volume Samplers

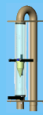

Work		Value	current
		0 1440 min	00 104 min
43 % 	538 l/min 	22,1 °C 919 hPa	507 l/min 20,9 °C 971 hPa
HVS 1 MPU 			
We, 13.02.2013 09:26:31		Menu	







## DIGITEL Aerosol Sampler DHA-80

High Volume Sampler (HVS) for autonomous, continuous measurements

The DHA-80 offers the following features:

- Automatic filter change, magazine for 15 filter holders, filter diameter 150 mm
- Constant and precise volume flow adjustable from 100 to 1'000 l/min (6 to 60 m<sup>3</sup>/h )
- Exact flow rate volume determination by the regulation of the air volume “enviro-drive” developed by DIGITEL
- Suitable for PM10 measurements according to EN12341 with the accredited DIGITEL PM10 inlet as well as PM2,5 and PM1 measurements, the DIGITEL PM1 inlet was developed in collaboration with the Duisburg Institute for Aerosol Research
- Easy to use programming with touch screen; menu driven program, controlling, monitoring and data logging with an integrated microprocessor, USB port for data logging
- Communication with other host system, smooth integration in available measuring networks via RS-232C interface, modem, radio modem and Ethernet
- Low maintenance in handling MTBF of the fast-frequency blower min. 36'000 hours
- Field housing, cabin housing and 19” rack housing available

# Our High Volume Samplers





# DHA-80 Compressor Cooled Sample Storage



## Specification as DIGITEL Aerosol Sampler DHA-80

- Additional cooling module for the filter storage.
- The filter storage is closed with an isolated cover (PM 2.5 / PM 10 Normative EN12341 / EN 14907: Recommendation for maximum filter storage and transportation temperature of 21°C).
- Temperature, control hysteresis, deicing intervals (with heating) and air circulation in the filter storage can be defined individually.
- Air floated housing minimizes the influence of solar irradiation.
- Blower is encapsulated, the blower's waste heat is channeled directly outside the housing.
- Additional ventilators for: floating of housing, air circulation in the filter storage, cooling of compressor.

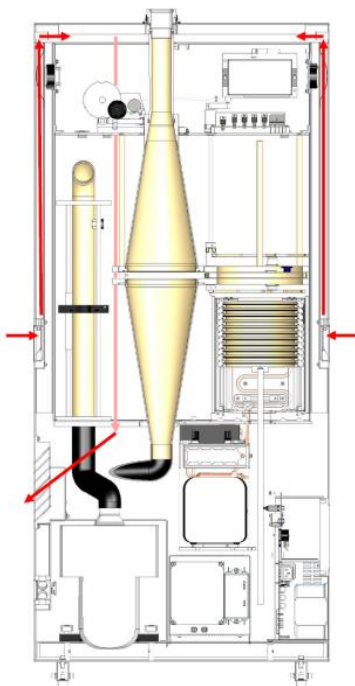

# Our High Volume Samplers





## DIGITEL Aerosol Sampler DH-77

High Volume Sampler (HVS) Single filter unit for autonomous and continuous measurements.

The DH-77 features:

- Manual filter change. One filter holder for a filter diameter of 150 mm
- Continuous and accurate volume flow, adjustable from 100 to 1'000 l/min (6 to 60 m<sup>3</sup>/h)
- Exact flow volume determination by the air flow regulation “enviro-drive” developed by DIGITEL
- Suitable for PM10 measurements according to EN12341 with certified DIGITEL PM10 inlet as well as PM2,5 and PM1 measurements
- Easy to use programming with integrated touch screen interface, menu driven program, controlling, monitoring and logging by integrated microprocessors onto USB
- Communication with other systems, smooth integration in all measuring networks via RS-232C interface, modem, radio modem and Ethernet
- Low maintenance handling, MTBF of rapid frequency turbine 36'000 hours
- Components can be delivered separately for self assembly

## DIGITEL Blower DS-02

Controlled High Volume blower for autonomous and continuous measurements. The DS-02 is similar to the DH-77 but the samples are taken outside the instrument. Features differing from DH-77:

- Easy to use programming with integrated key pad and LCD-display, menu controlled programming, controlling, monitoring and logging with integrated microprocessors
- Communication with other systems, smooth integration in available measuring networks via RS-232C interface, modem, radio modem, Ethernet
- For external filter heads, inlets, cartridges, etc.



Background measurement site in Scotland

Our cartridge changers can be installed instead of the lower filter cone in line with the round paper filter. They are suitable for PUR foams, granulates or other materials. The options can be refit to basic instruments.



## Single cartridge holder

- Single cartridge holder is mounted in standard instrument replacing the cone after the filter
- PTFE sealings
- Internal dimensions max.:  $d = 100 \text{ mm}$ ,  $l = 140 \text{ mm}$  (other dimensions on request)
- Including two spare glass tubes or blind pipes of enamelled aluminum, a screen and two transport-closure-caps.

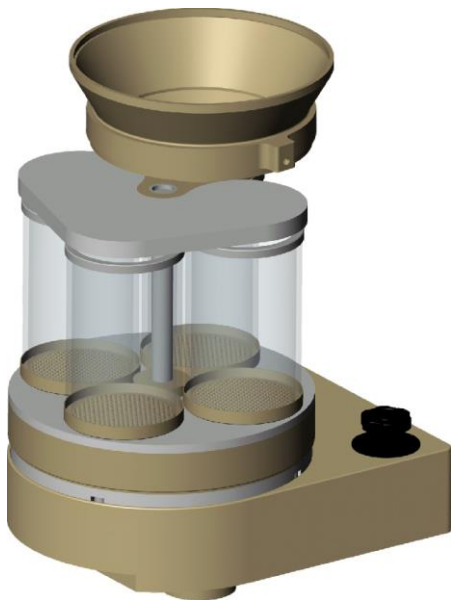

## Automatic cartridge changer

- with four cartridges ( $d=60\text{mm}$ ,  $l=100\text{mm}$  inside)
- 8 cartridges, 8 grids and 4 transport boxes are included
- Cartridges that are not in the air flow are sealed
- Successive periods can be programmed independently for each cartridge
- Attention: the automatic cartridge changer is available for non-climatized instruments only!



## Options – Data logging



### Thermo printer DTD02

With bracket for easy fastening and 10 rolls of paper



### USB printer retrofit

Prints your data onto a USB stick.  
Attention: no internal memory, stick has to be plugged at all times

## Options – Meteo sensors



### Wind sensor

For wind controlled sampling



### Ambient pressure and temperature sensor

Allows automatic calculation of exact flow values depending on ambient conditions



Measurement site on Sonnblick, 3106 AMSL, Austria



### Empa sampling probe

TSP Inlet (measurement of Total Suspended Particles )

- Incl. tube (d = 40/44 mm, l = 1 m)
- Ematalated aluminum



### DIGITEL High Volume PM10 inlet DPM10/30/0

suitable for PM10 measurements

- Audited according to EN12341 10 $\mu$ m separation at 30 m<sup>3</sup>/h
- Upper part rocking enables an easy cleaning of the impactor
- Secured vice action latches
- All parts are made of ematalised aluminum
- Cannon surface heatable
- Baffle pot can be removed for cleaning





### DIGITEL High Volume PM2,5 inlet DPM2,5/30/00

- Audited according to EN14907
- 2,5  $\mu\text{m}$  separation at 30  $\text{m}^3/\text{h}$
- Upper part rocking enables an easy cleaning of the impactor
- Secured vice action latches
- All parts made of ematalised aluminum
- Cannon surface heatable
- Baffle pot can be removed for cleaning



### DIGITEL High Volume PM01 inlet DPM01/30/00

- For PM01 measurements
- 1 $\mu\text{m}$  impaction at 30  $\text{m}^3/\text{h}$
- 2-stage impactor:
  1. Stage PM 2,5 at 30  $\text{m}^3/\text{h}$
  2. Stage PM 1 at 30  $\text{m}^3/\text{h}$
- Both upper parts are rocking, enabling an easy cleaning of the impactor
- Secured vice action latches
- All parts made of ematalised aluminum
- Cannon surfaces heatable
- Also available for 23,1  $\text{m}^3/\text{h}$
- Baffle pots can be removed for cleaning

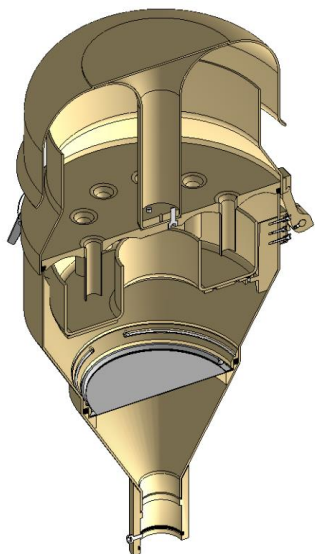

### Inlet with filter holder

- The Digital Inlets for PM10, PM2.5 and PM1 can also be delivered with integrated filter holder
- Use with DS-02



### Fly screen

- Fly screen for DIGITEL HVS sampling heads PM1, PM2.5 and PM10
- Can easily be removed for cleaning

- Optional heating available for all inlets
- Baffle pots and nozzle plates can be delivered separately

## Filter holder



- Filter holder: for filter diameter 150 mm. (140 mm flown)
- Weight : 250 g
- Diameter: 174 mm
- Height : 12,5 mm
- Material: ematalized aluminum with a screen of stainless steel and Teflon ring
- Sold single or as a set of 15pcs
- Other sizes on request

## Cartridges



- Glass tubes for PUF hand cartridges, covers, grids
- Glass tubes for PUF automatic cartridge changer, boxes, grids



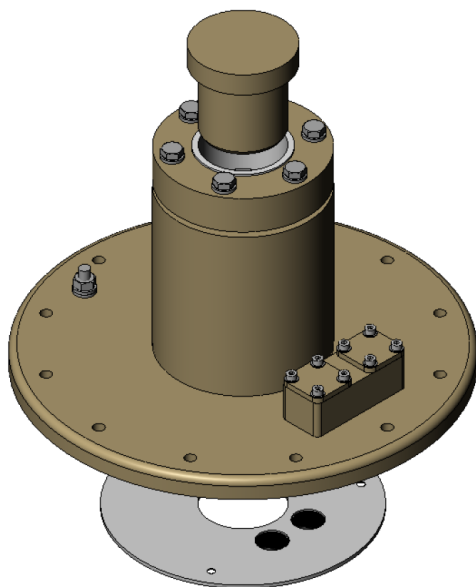

### Roof pass for a flat roof

- Ematalised aluminum with Teflon stuffing box and closure cap,
- Roof passes for following pipe diameters are standard: 16 mm; 32 mm; 40 mm; 44 mm; 45 mm. (other dimensions on request)
- With or without cable pass for heating and sensors



### Rain drip rail

- For DIGITEL High Volume Sampler in field housing
- White powder coating
- Stopps water accumulation at the upper side of the door

### Extension pipes

Ematalised aluminum (pipe internal all-ematalised).

External diameter: 44 mm, internal diameter: 40 mm, lengths: 80 mm - 2,5m  
(Standard lenght: 0,5 m; 0,75 m; 1 m; 1,5 m; 1,7 m; 2 m; 2,5 m)

### Feet extensions

Enhanced stability for Digitel High Volume Samplers in field housing

### Fastening set

For DHA-80 in field housing, existing of: two holders (ematalised aluminum), two stainless bolts and nuts for fastening on concrete or wooden floors



Measurement site in Magadino, Switzerland



### Calibration unit

- Calibration unit 100-1'000l/min
- Or calibration unit 420-600l/min
- Including testing certificate



### Transport case for calibration unit

for transport of a calibration unit with sleeve and sliding collar. Beechen case, colourless water-based varnish, 4 feet, inside not varnished with a polyurethane padding, 2 hinges, 1 handle and a pocket for the testing certificate.

- Dimensions: l = 660 mm; W = 220 mm; H = 130 mm
- Delivery without calibration unit



## Spare Parts



### Blower

- 3-stages
- 200 Hz
- 1520 W
- MTBF > 36'000 h



### Fastening set for blower

Prints, hoses, other spares

We can supply spares for 10 years after sale. Please add the instrument's serial number and a photo, a drawing or a description of the needed spare to your request.

## Consumables

- Glass fibre filter, d = 150 mm
- Quartz fibre filter, d = 150 mm
- Sealing rings (O-Rings) for pipe connections and filter holders
- Sealing ring kits for complete instruments (DHA-80, DH-77)
- Thermo paper for Thermo printer DTD02
- Silicone paste



This booklet only shows a part of our wide product range. Data sheets, dimensional drawings and program, updates are available on our homepage [www.digitel-ag.com](http://www.digitel-ag.com).

For further information and specification of our instruments as well as for quotations and custom products please contact our local representatives.

No responsibility is taken for the correctness of the details provided in this catalogue, the instruments delivered can differ from the pictures in the catalogue. Special thanks to EMPA for the pictures of the NABEL measurement stations and to our local representatives for their nice pictures.

Digitel Elektronik AG 2013



DIGITEL Elektronik AG  
Alte Gasse 18  
CH-8604 Hegnau

Telefon +41 44 908 20 30  
[digitel@digitel-ag.com](mailto:digitel@digitel-ag.com)  
[www.digitel-ag.com](http://www.digitel-ag.com)